

DISPENSERS ST 200 AC

**MADE
IN
ITALY**

EN. High flow rate portable dispenser unit. ST 200 dispenses diesel fuel at a rate of up to 200 l/min and controls the flow with great precision (+/- 1%) thanks to the oval-gear flow meter (on request).

The low weight of the unit and the possibility of fitting wheels make it easy to handle and suitable for operating on worksites on vehicles with large storage tanks. The unit features a sturdy steel frame.

ES. Unidad móvil de trasiego alta capacidad. ST 200 suministra gasoleo hasta 200 l/min y controla el flujo con precisión (+/-1%) con el cuentalímetro mecánico de engranajes ovalados (a petición).

El peso limitado y la posibilidad de instalar ruedas lo hacen manejables y apto por trasiegos por vehículos con largo tanque en obras. Con robusto chasis en acero.

RU. Высокопроизводительный переносной узел подачи. ST 200 подает дизельное топливо со скоростью до 200 л/мин и контролирует поток с точностью (+/- 1%) благодаря счетчику литров с овальными шестернями (по заказу).

Уменьшенный вес и возможность установки колес повышают маневренность и позволяют использовать его на стройплощадках для заправки транспортных средств с баками большого объема. Оснащен прочной стальной рамой.

PERFORMANCE

- Flow rate up to 200 l/min
- Continuous AC operation.
- Noise level below 75 dB

- Caudal hasta 200 l/min
- Funcionamiento continuo CA
- Nivel sonoro inferior a 75 dB

- Расход до 200 л/мин
- Непрерывное функционирование от электросети
- Уровень шума ниже 75 дБ

DIMENSIONS

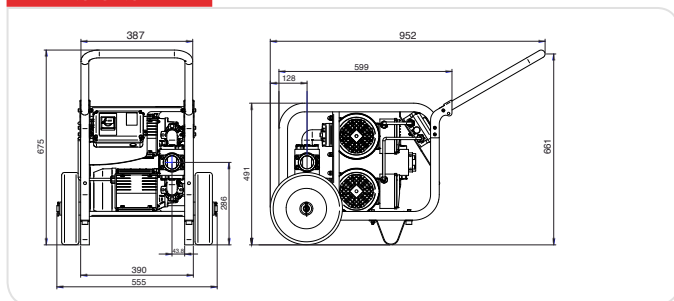

PRODUCTS' RANGE WEIGHT AND PACKAGING

Code	Weight		Packaging		
	kg	lbs	mm	inch	pcs/box
F00315000	46	101	587x395x420	23,1x15,6x16,5	1
F16860000	-	-	-	-	-

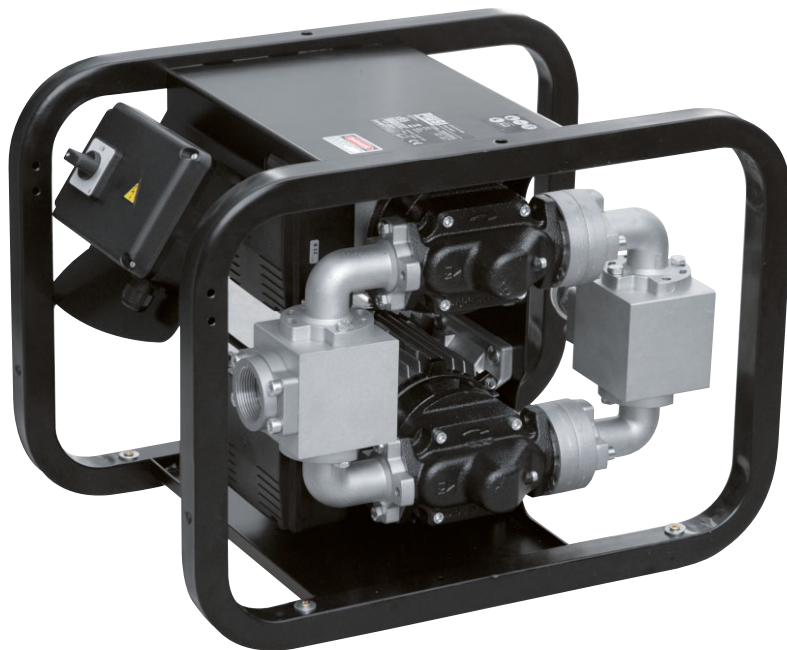

Flow-rate
up to
200 l/min
(up to 52,7 gpm)



DISPENSERS

PUMPS

METERS

NOZZLE METERS

NOZZLE

SPECIAL EQUIPMENTS

FLUID MONITORING

ACCESSORIES

FILTERING

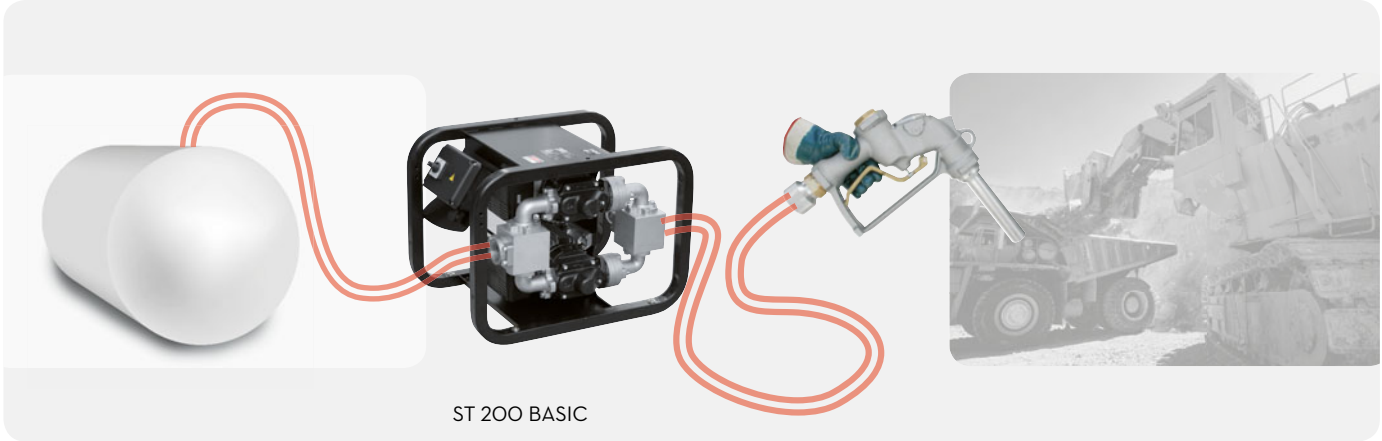

ST 200 BASIC



HANDY KIT: version with wheels and handle.

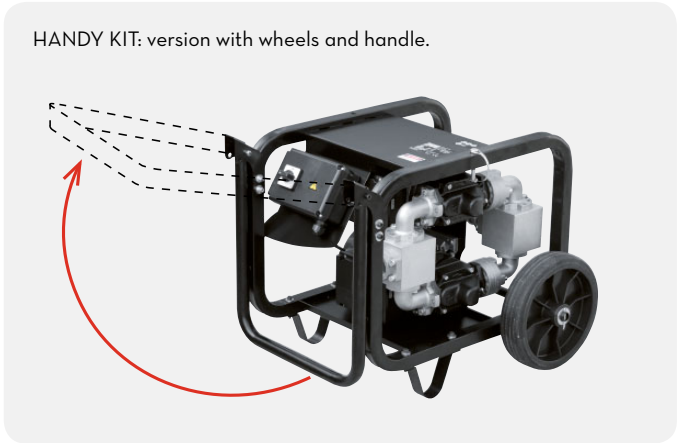

FEATURES

Electric cable



Electric cables length 6 mt

On/off switch



ON REQUEST

Meter K700 M



Flow rate: 20 - 220 l/min
Accuracy: +/- 1%
Oval gear system
Code: FO0540000

Nozzle A280



Flow rate 280 l/min with swivel
Code: F13249000

Hose Kit 1" 1/2



Code: F18798000 (hose 10 mt + Camlock)
Code: F18799000 (hose 20 mt + Camlock)

PRODUCTS' RANGE TECHNICAL DATA

Code	Description	Fluids type	Flow-rate		Voltage			Pump		Max pressure bar	Inlet BSP
			l/min	gpm	AC V./Hz	Power Watt	Amp. max.	mod.	no.		
F00315000	ST 200 BASIC	D	200	52,7	230/50	2050	10	E 120	2	2,5	1" 1/2
F16860000	HANDY KIT (handle + wheels)	D	-	-	-	-	-	-	-	-	-

Upon request it is available with different voltages and 60 Hz frequency